

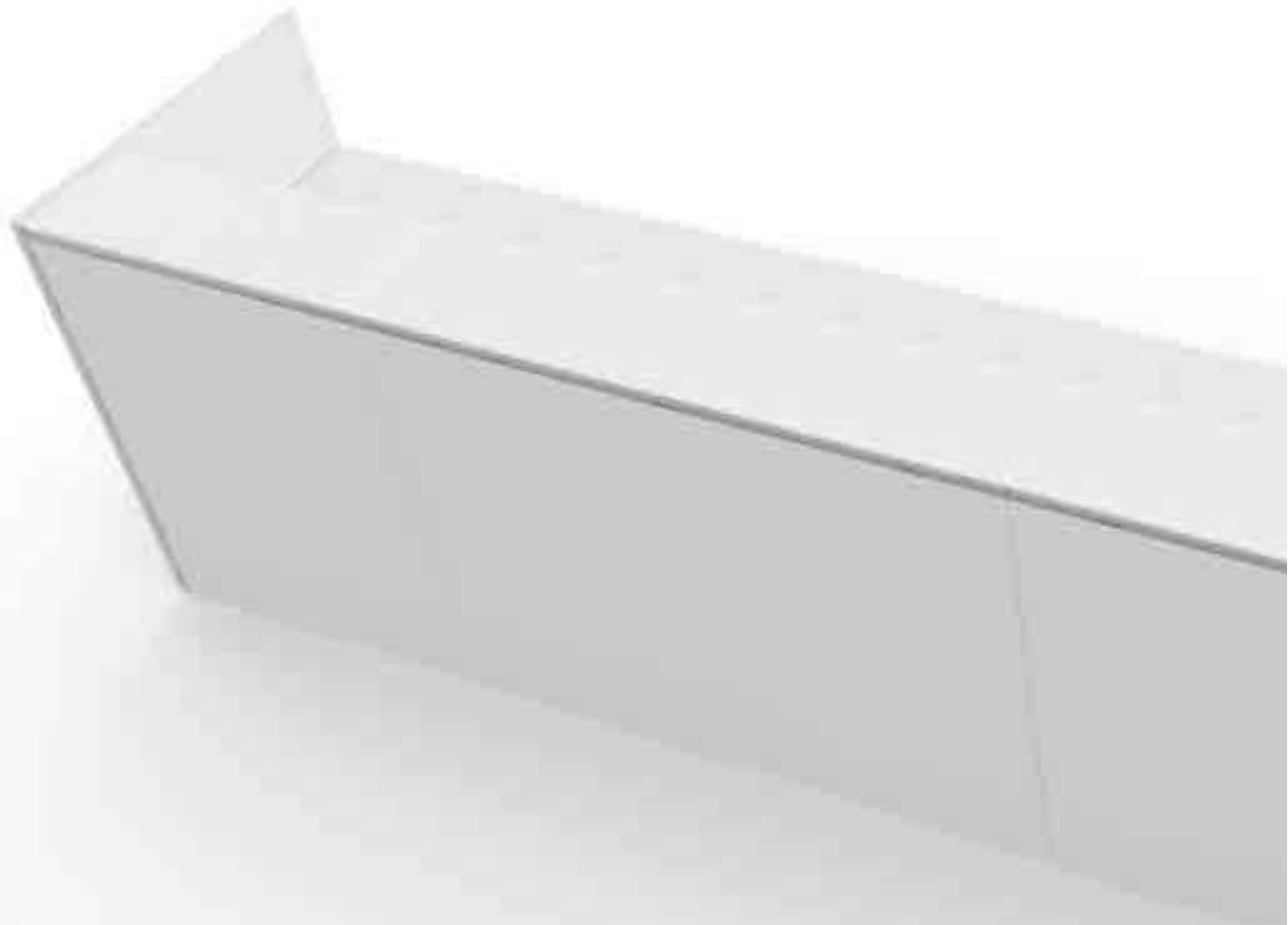

QUBO 01



.01



04 | 09

.02



10 | 15

.03

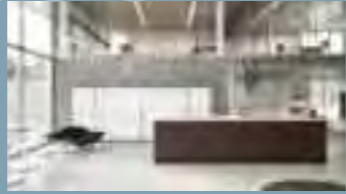

16 | 21

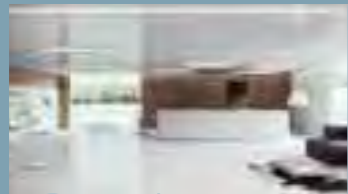

.04

22 | 27

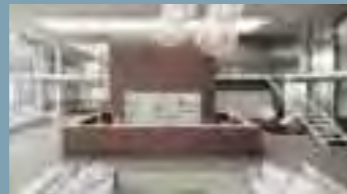

.05

28 | 33



.06

34 | 39



LAMBDA3
INSPIRANDO ESPACIOS DE TRABAJO



QUBO.

Minimalismo e pulizia progettuale.

QUBO si presenta come elemento dedicato all'accoglienza. Caratterizzato da elementi semplici che, accostati tra di loro, definiscono lo spazio di primo contatto. Conferisce alla reception un'immagine fresca e dinamica.

Minimalism and clean design.

QUBO is a modular reception desk solution. It's characterized by its simple in-line modules for defining the space of the first contact, giving the reception a fresh and dynamic image.

QUBO.

MINIMAL

DESIGN

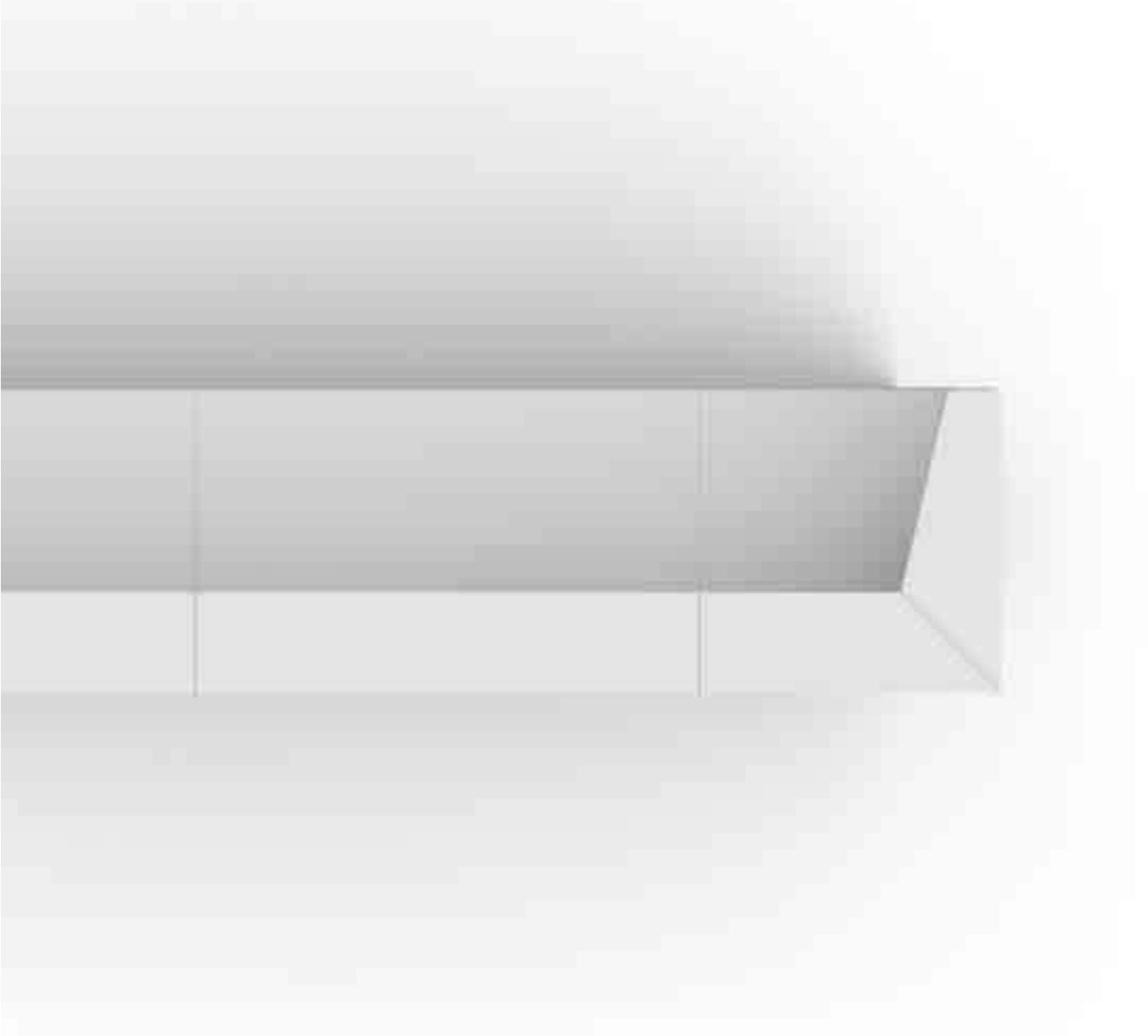

Cinque tipologie di moduli consentono di ottenere composizioni in grado di soddisfare qualsiasi esigenza funzionale.

Five ranges of elements allow for configurations to satisfy any functional requirement.

QUBO.00



QUBO.01

QUBO.01



Purezza delle forme e massima linearità della composizione per un risultato dal sapore minimalista. Il grande bancone reception in rovere chiaro si adatta a qualsiasi ambiente grazie ai suoi requisiti estetici e costruttivi.

The clean lines of the range give a minimalist appearance. The large reception desk in light oak adapts to any room, thanks to its aesthetic and structural integrity.



Il piano di lavoro può essere attrezzato con funzionali box multiuso in melaminico, da posizionare a piacere sotto il top, nella soluzione orizzontale o verticale.

The working top can be augmented with the melamine multi function box, that can be placed either horizontally or vertically under the top.



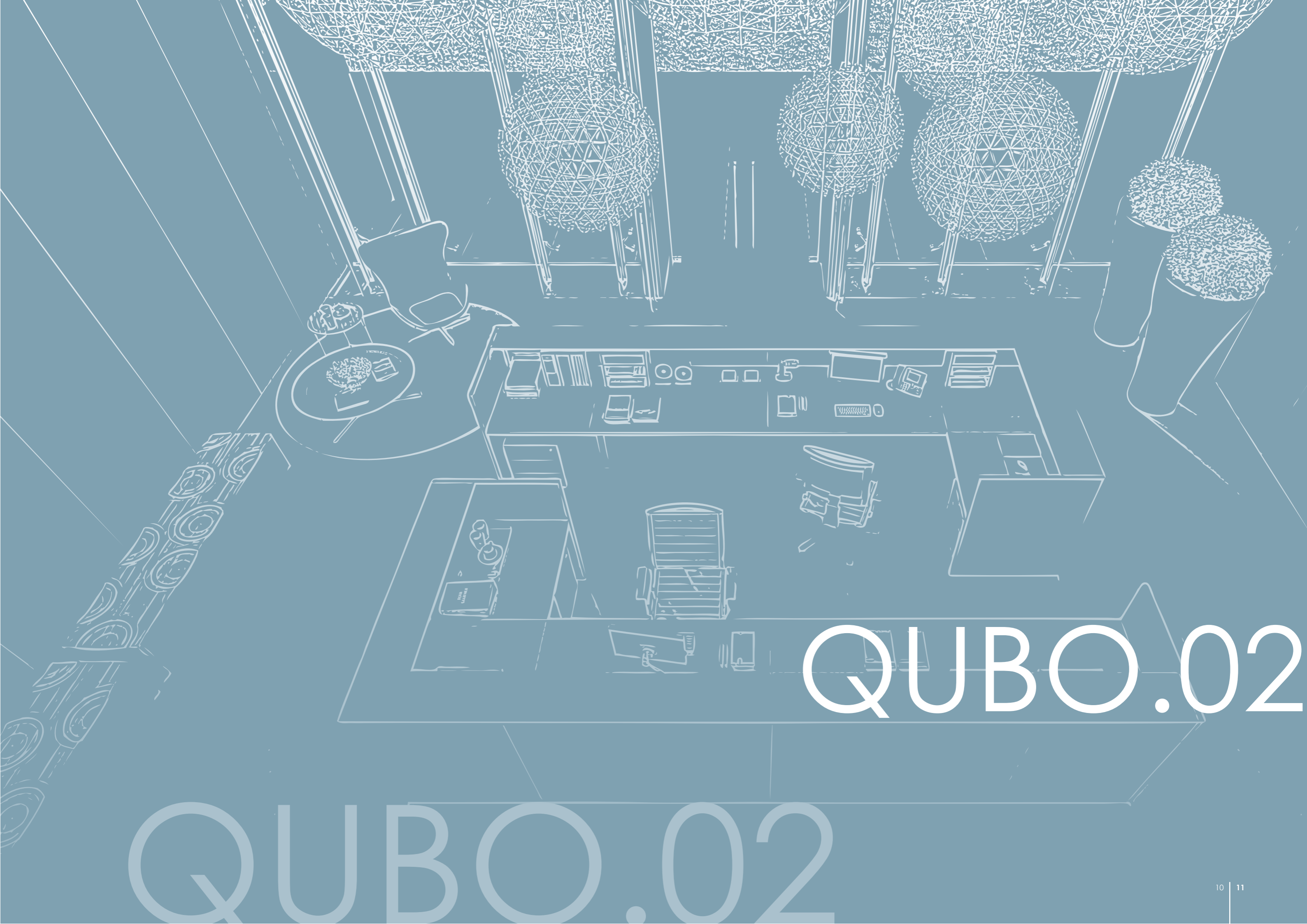

QUBO.02

QUBO.02



Nella grande hall aziendale, trova la sua massima espressione la soluzione a 360°.
La reception a doppio affaccio diventa il cuore organizzativo per le relazioni esterne ed interne facilitando dialogo e scambio.

In a large space the 360 configuration demonstrates the product at its best.
The reception with double front provides the organizational heart both for external and internal relations, facilitating dialogue and exchange.



Forma e funzione si fondono con armonia attraverso l'eleganza delle finiture cromatiche.
Form and function blend harmoniously with the elegant chromatic finishes.



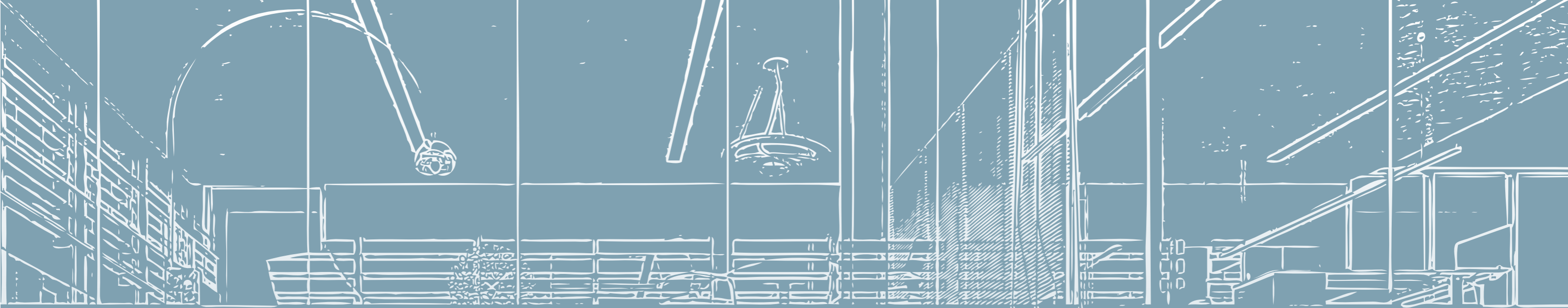

QUBO.03

QUBO.03



Il disegno ricercato e particolare dei top terminali, caratterizza e rende riconoscibile lo stile di QUBO, anche nelle composizioni più semplici e lineari.

The particular design of the terminal tops provides the character and style of QUBO, even in the most simple and linear of compositions.



Facili e decisi abbinamenti cromatici evidenziano la rigosità e la purezza della forma.

The varied colour combinations highlight the clarity of the design.



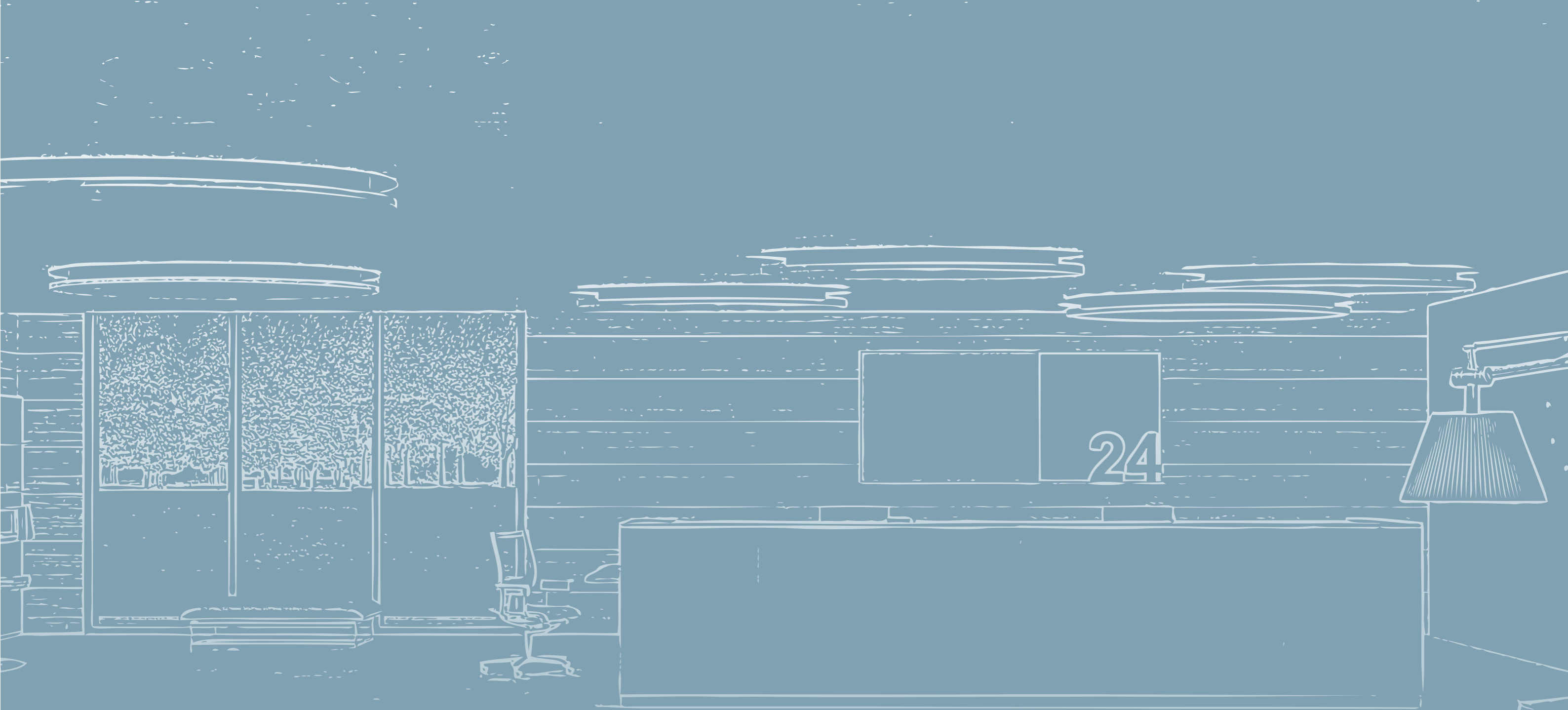

QUBO.04

QUBO.04



Le diverse modularità previste nella collezione, permettono di realizzare svariate composizioni. La tipologia ad "L" consente di progettare reception ad angolo che si interfacciano armoniosamente con il resto dell'ambiente.

The different modules offered within the range allow the creation of various compositions. The "L" shape allows for angled reception design in harmony with the rest of the space.



Il piano conversazione si integra perfettamente con i diversi moduli bancone e consente di creare uno spazio di grande utilità sia per gli operatori che per il pubblico, senza compromettere l'estetica e la funzione della composizione realizzata.

The conversation worktop, seamlessly integrated within the different counter modules, gives a space of great use both to the operator and the public alike, without compromising the aesthetic and function of the counter-desk.



QUBO.05

QUBO.05



La soluzione compositiva ad "U" si presta in modo particolare ad essere inserita in grandi o importanti spazi destinati all'accoglienza. L'articolazione su tre fronti, genera un'ampia superficie lineare per il dialogo con il pubblico. Le finiture rovere tabacco e bianco lucido caratterizzano il volume con delicata eleganza.

The "U" shaped configuration is particularly suitable when used in large or important areas for the reception. Its three fronted composition gives a large area for interacting with the public. The Tobacco Oak and Glossy White finishes highlight its refined shape.



Questa soluzione prevede l'integrazione dei mobili di servizio di libera installazione che, in questo caso, incrementano la funzionalità a supporto dell'operatore, delimitando con semplicità e leggerezza le aree di lavoro.

This solution allows the integration of freestanding service units, increasing the functionality for the operator, providing the workspaces with a simplicity and lightness.





1

2

3

4

QUBO.06

QUBO.06



QUBO è stato pensato per adattarsi a qualsiasi situazione di reception e front-office. Grazie alla flessibilità e alla modularità dei suoi elementi, si possono creare postazioni singole, multiple, lineari o articolate destinate alle diverse e specifiche attività legate all'interazione con il pubblico.

QUBO is designed to adapt to any reception area or front office. Thanks to the flexibility and modularity of its components, you can create individual or multiple workplaces, either in-line or shaped, to meet the varied and specific activities involved in interacting with the public.

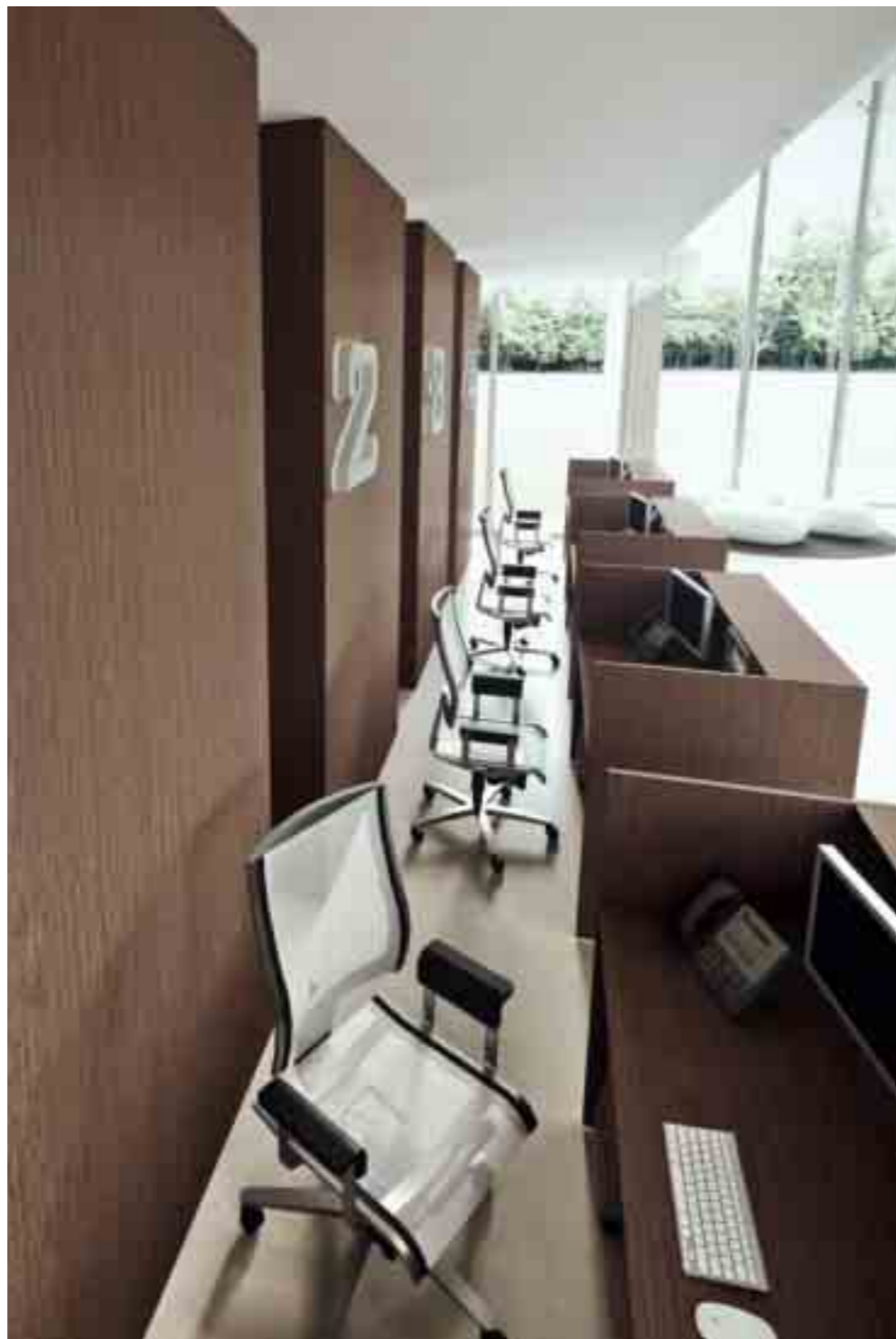



ABACO

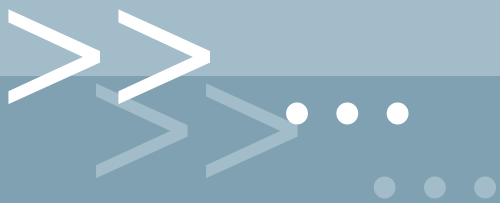

ABACUS

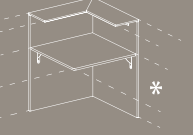
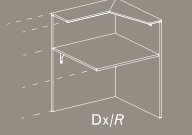
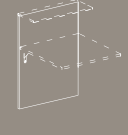
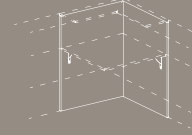

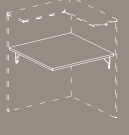
MODULI BANCONE - COUNTER MODULES

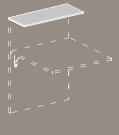
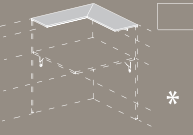
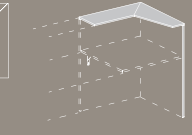

<p>P 84 - H 112 Moduli dritti Straight modules</p>  <p>QU8080_ L 80 QU8140_ L 140 QU8160_ L 160</p>	<p>L 84 - P 84 - H 112 Raccordo 90° a 2 vie 2 ways 90° connection module</p>  <p>QU8010_</p>	<p>L 84 - P 84 - H 112 Terminale 90° Dx/Sx R/L 90° terminal modules</p>  <p>QU8011_ Dx/R QU8012_ Sx/L</p>	<p>P 2,5 - H 110 Schiene per moduli dritti Back panels for straight modules</p>  <p>QU7080_ L 80 QU7140_ L 140 QU7160_ L 160</p>	<p>L 84 - P 84 - H 110 Schiene per moduli 90° Back panels for 90° modules</p>  <p>QU7010_</p>	<p>P 80 - H 2,5 Piani scrivania per moduli dritti Worktops for straight modules</p>  <p>QU0080_ L 80 QU0140_ L 140 QU0160_ L 160</p>	<p>L 80 - P 80 - H 2,5 Piani scrivania per moduli 90° Worktops for 90° modules</p>  <p>QU0010_</p>
--	---	--	---	---	---	---

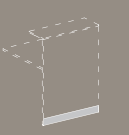
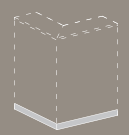
COMPONENTI PER MODULI BANCONE - COMPONENTS FOR COUNTER MODULES

<p>P 30 - H 1,8 Top per moduli dritti Top for straight modules</p>  <p>QU6080_ L 80 QU6140_ L 140 QU6160_ L 160</p>	<p>L 84 - P 84 - H 1,8 Top per raccordo 90° a 2 vie Top for 90° modules</p>  <p>QU6010_</p>	<p>L 84 - P 84 - H 1,8 Top per terminali 90° Dx/Sx R/L top for 90° terminal modules</p>  <p>QU6011_ Dx/R QU6012_ Sx/L</p>	<p>L 84 - P 2,5 - H 112 Fianchi terminali Dx/Sx R/L terminal sides</p>  <p>QU1081_ Dx/R QU1080_ Sx/L</p>	<p>L 5 - P 5 - H 71 Colonna intermedia Intermediate slim column</p>  <p>QU0020H</p>	<p>P 2,5 - H 8 Zoccoli per moduli dritti Metal base for straight modules (Optional)</p>  <p>QU2080H L 80 QU2140H L 140 QU2160H L 160</p>	<p>L 84 - P 84 - H 8 Zoccoli per moduli 90° Metal base for 90° modules (Optional)</p>  <p>QU2010H</p>
--	--	--	---	--	---	--

* Non utilizzabile come terminale / It cannot be used as a terminal side

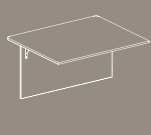
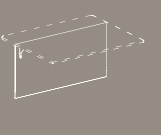
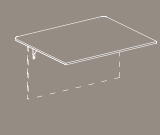

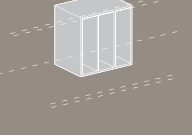

MODULI BANCONE CON PIANO CONVERSAZIONE - COUNTER UNIT WITH CONVERSATION TOP

<p>L 140 - P 115 - H 73,5 Modulo conversazione Conversation counter module</p>  <p>QU9140_</p>	<p>L 140 - P 2,5 - H 71 Schiene per modulo conversazione Back panels for conversation module</p>  <p>QU7141_</p>	<p>L 140 - P 115 - H 2,5 Piano per modulo conversazione Worktop for conversation module</p>  <p>QU0141_</p>	<p>L 84 - P 2,5 - H 73,5 Fianchi terminali per modulo conversazione Terminal sides for conversation module</p>  <p>QU8095_ Dx/R QU8096_ Sx/L</p>	<p>L 28 - P 2,5 - H 38,5 Fianchetti superiori per modulo conversazione Small sides for conversation module</p>  <p>QU0024_ Dx/R QU0025_ Sx/L</p>	<p>L 35,5 - P 24 - H 35,5 Box multiuso / Multipurpose Box</p>  <p>AC8200_</p>
---	---	--	---	---	--

Componenti non collegabili con modulo conversazione / Items that cannot be connected with the conversation counter units





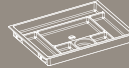
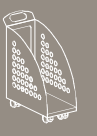
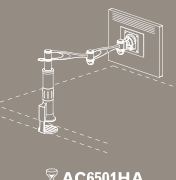

Gli zoccoli sono optional e non sono previsti per i fianchi terminali / The aluminium bases are optional and are not intended for end panels

CASSETTIERE - PEDESTALS

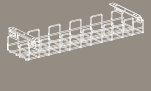
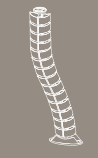
<p>L 42,5 - P 65 - H 71</p>  <p>QU3062_ Melaminico/Melamine</p>	<p>L 42,5 - P 57 - H 56</p>  <p>QU3001_ Melaminico/Melamine</p>	<p>QU3002_ Melaminico/Melamine</p>	<p>L 42 - P 57,5 - H 52,5</p>  <p>AC3001_ Metalliche/Metallic</p>	<p>AC3002_ Metalliche/Metallic</p>	<p>L 39 - P 54,5 - H 3,5</p>  <p>AC3015 Cuscino/Cushion</p>	<p>AC6530H Rallentatore per cassetto Soft-closing for drawer</p>  <p>AC4427 L 33 AC4425 L 39</p>	<p>AC0434G</p> 	<p>AC0508_G</p> 	<p>AC6501HA</p> 
--	--	------------------------------------	--	------------------------------------	--	---	--	---	---

= Fino ad esaurimento / Until exhaustion

CANALIZZAZIONE / ELETTRIFICAZIONE - WIRE - MANAGEMENT | ELECTRIFICATION

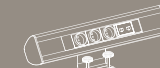
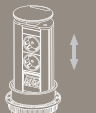
<p>AC1559H L 45 AC1550H L 58 AC1552H L 110 AC1553H L 140</p> 	<p>AC0510H</p> 	<p>AC0521H</p> 	<p>AC0377HR_ ø 8</p> 	<p>AC0372G_ ø 6 AC0376G_ ø 8</p> 	<p>AC0512R ● AC0512R - UK ● AC0512R - US</p> 	<p>AC0511R ● AC0511R - UK ● AC0511R - US</p> 	<p>AC0381H ● AC0381H - UK ● AC0381H - US</p> 	<p>AC0380H ● AC0380H - UK ● AC0380H - US</p> 
--	--	--	--	--	--	--	--	--

Articoli prodotti solo su richiesta / Items produced only on demand

Prodotti non in pronta consegna. Per la disponibilità contattare l'ufficio commerciale / Items not in prompt delivery. Please contact the commercial department for checking the availability

NOTA BENE - NOTES

Progettare la composizione del bancone ed aggiungere: n° 1 colonna intermedia per ogni collegamento tra due moduli; n° 1 fianco terminale dx/sx, o fianco conversazione dx/sx, o angolo terminale 90° dx/sx per ogni lato finale del bancone; n° 1 fianchetto superiore dx/sx per ogni collegamento tra modulo conversazione e modulo bancone. Gli zoccoli sono optional e non sono previsti per i fianchi terminali. / When you design the composition of a counter you have to add: no. 1 intermediate column for each link between two modules; for each end side of the counter; no. 1 right/left terminal panel; or right/left conversation side panel; or right/left terminal 90° corner-element; no. 1 right/left upper short-side-panel for each connection between a counter module and a conversation module. The aluminium bases are optional and are not intended for end panels.

N.B.: LE DIMENSIONI SONO ESPRESSE IN CM - CONSULTARE IL LISTINO PREZZI PER LE CARATTERISTICHE TECNICHE, I CODICI DEGLI ARTICOLI E DELLE FINITURE.
N.B.: DIMENSIONS ARE STATED IN CM - FOR TECHNICAL CHARACTERISTICS, ARTICLE CODE NUMBERS AND FINISHING SEE PRICE LIST.

MODULI BANCONE COUNTER MODULES



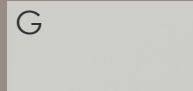
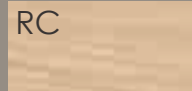
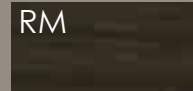
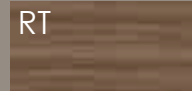

Piani di lavoro in melaminico sp. 25 mm con bordi in ABS sp. 2 mm
Melamine working tops 25 mm thick with ABS edges-profile 2 mm thick

<p>W-WN</p>  <p>Bianco White</p>	<p>G</p>  <p>Grigio chiaro Light grey</p>	<p>RC</p>  <p>Rovere chiaro Light oak</p>	<p>RM</p>  <p>Rovere Moro Dark oak</p>	<p>RT</p>  <p>Rovere Tabacco Tobacco oak</p>
---	--	--	---	---

Pannelli verticali in melaminico sp. 25 mm con bordi in ABS sp. 1,5 mm
Vertical panels in melamine tops 25 mm thick with 2 mm ABS edges-profile 1,5 mm thick

<p>W-WN</p>  <p>Bianco White</p>	<p>G</p>  <p>Grigio chiaro Light grey</p>	<p>RC</p>  <p>Rovere chiaro Light oak</p>	<p>RM</p>  <p>Rovere Moro Dark oak</p>	<p>RT</p>  <p>Rovere Tabacco Tobacco oak</p>
---	--	--	---	---

Top in melaminico (*) o laminato (**) sp. 18 mm con bordi in PMMA bicolore sp. 1,5 mm
Melamine (*) or laminate (**) top 18 mm thick with bicoloured PMMA edges-profiles 1,5 mm thick

<p>W-WL**</p>  <p>Bianco Lucido Glossy White</p>	<p>G*</p>  <p>Grigio chiaro Light grey</p>	<p>RC*</p>  <p>Rovere chiaro Light oak</p>	<p>RM*</p>  <p>Rovere Moro Dark oak</p>	<p>RT*</p>  <p>Rovere Tabacco Tobacco oak</p>
---	---	---	--	--

COMPONENTI IN METALLO/ZAMA METAL COMPONENTS/ZAMAK

H

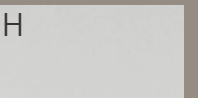

Alluminio
Aluminium

ZOCOLI IN ALLUMINIO ALUMINIUM BASE

Finitura alluminio anodizzato
Anodized aluminium finishing

H



Alluminio "ANODIZZATO"
"ANODIZED" Aluminium

BOX MULTIUSO MULTIPURPOSE BOX

Box in melaminico sp. 10 mm con bordi in ABS colore alluminio sp. 1 mm
Melaminated box 10 mm thick with ABS edges-profiles 1 mm thick

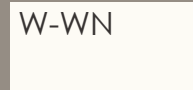
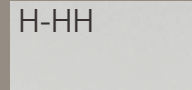
<p>W-WN</p>  <p>Bianco White</p>	<p>H-HH</p>  <p>Alluminio Aluminium</p>
---	--



¡ESCANÉAME!

LA TRANQUILIDAD DE CONTAR CON NUESTRAS SOLUCIONES

LAMBDA3
INSPIRANDO ESPACIOS DE TRABAJO

LAMBDA3, S.A.

Laguna de Cameros 8, 28021 Madrid

914 479 577

lambdatres@lambdatres.com

www.lambdatres.com