

DIESIS

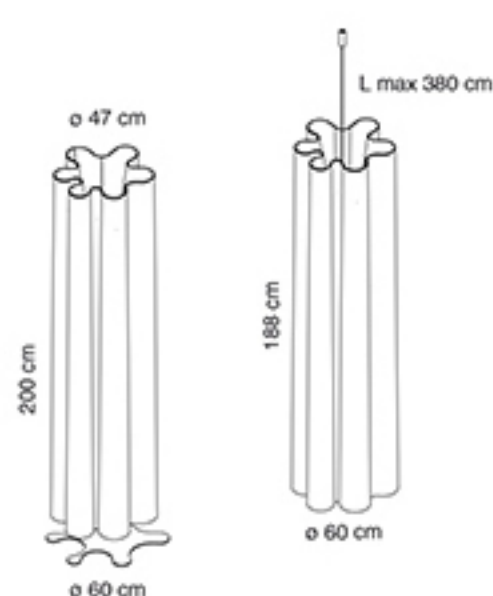

BEMOLLE

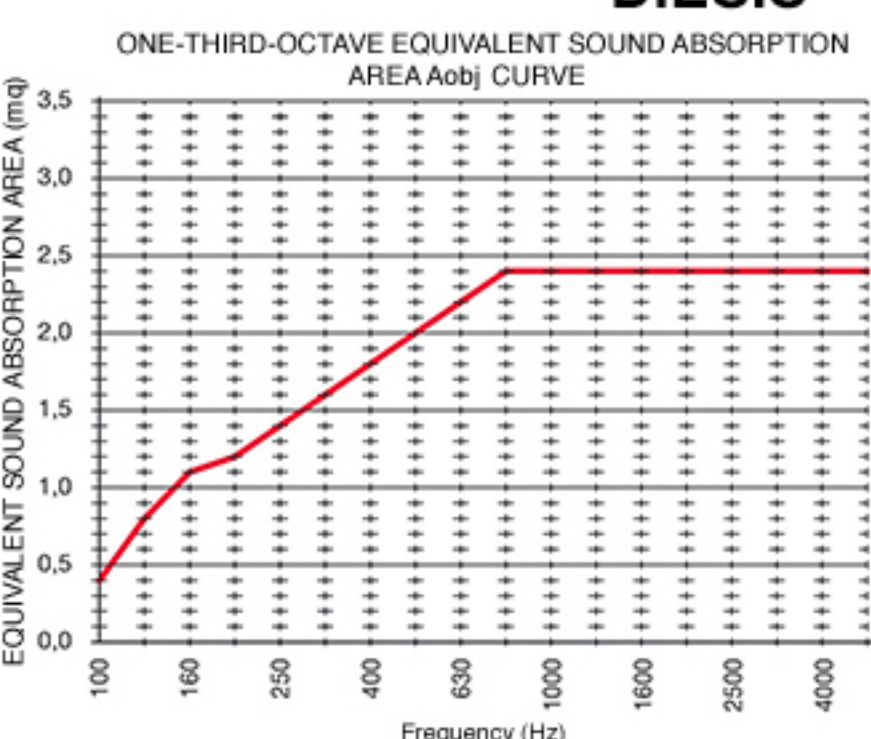
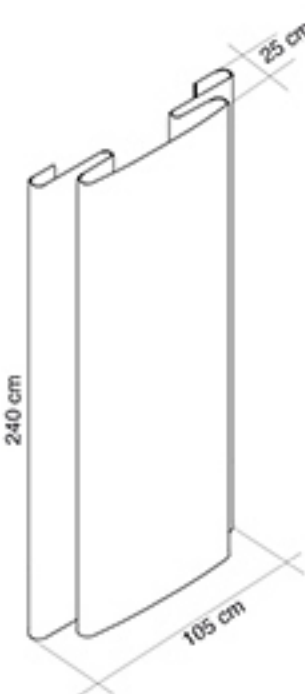
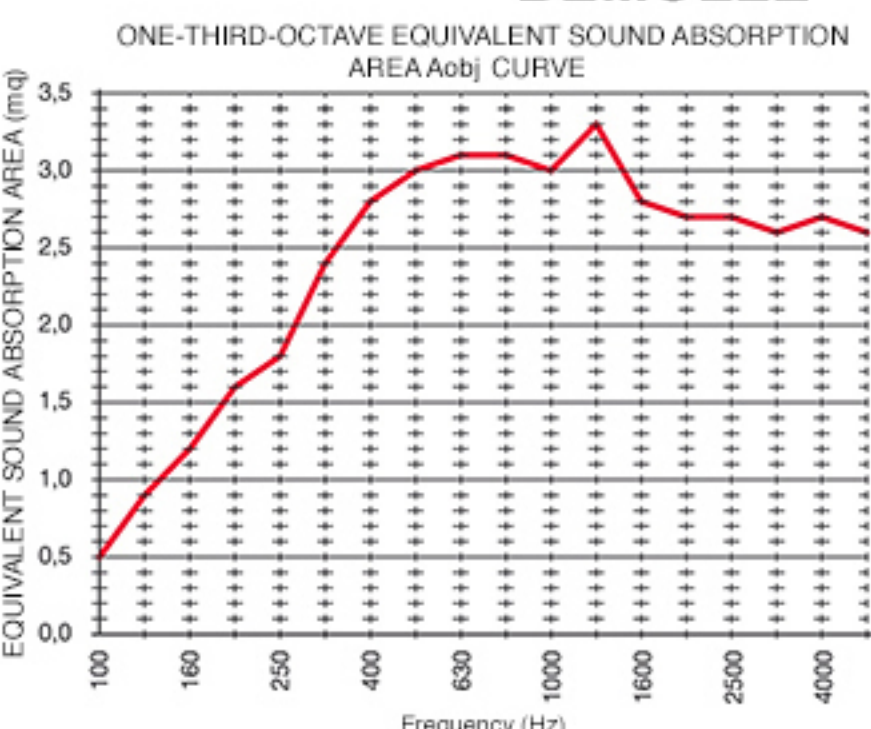

SIPARIO

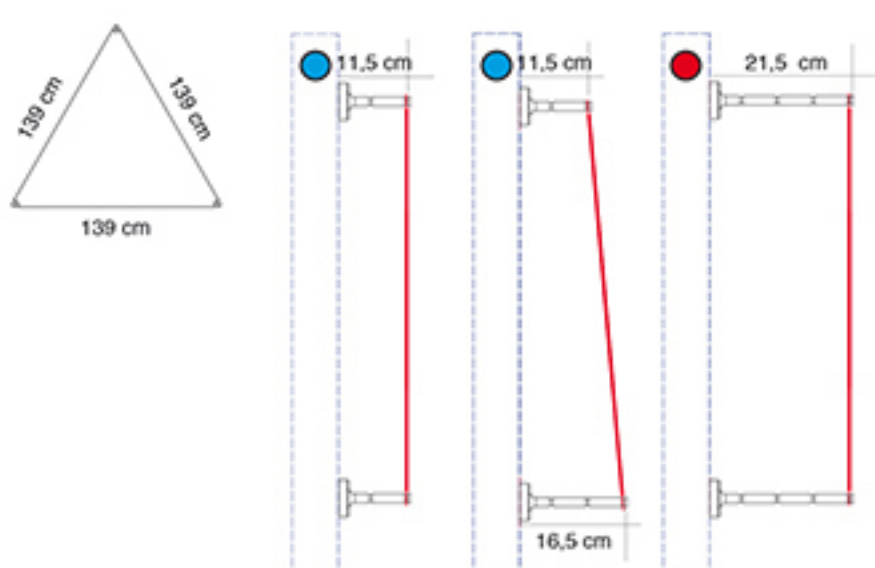
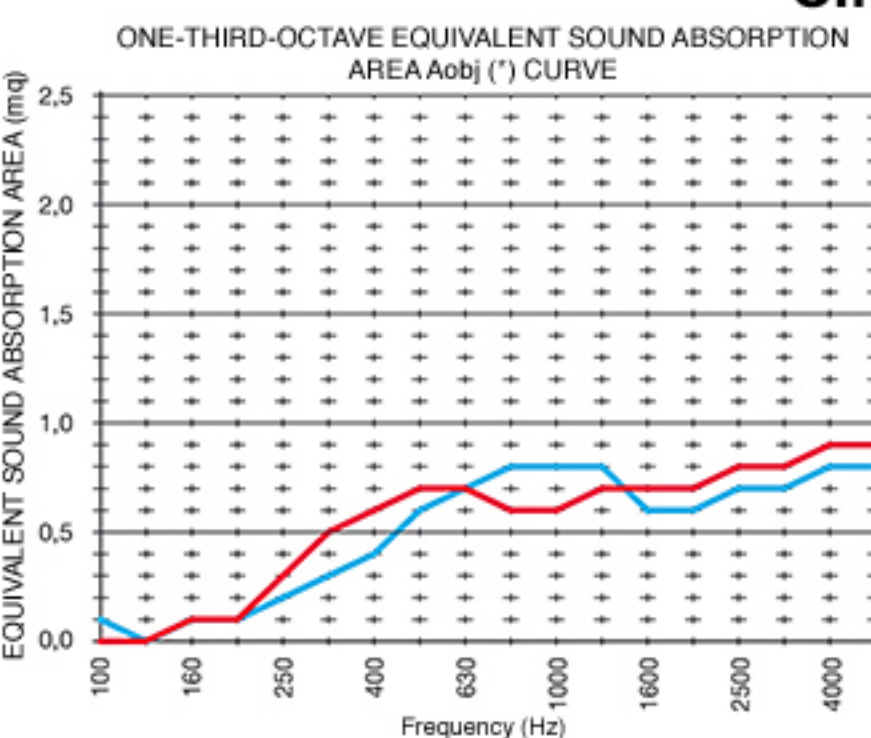

(*) In case of inclined panels, the values of Equivalent sound absorption area Aobj refer, as a precaution, to panels mounted straight with the shortest distance from the wall.

SIPARIO

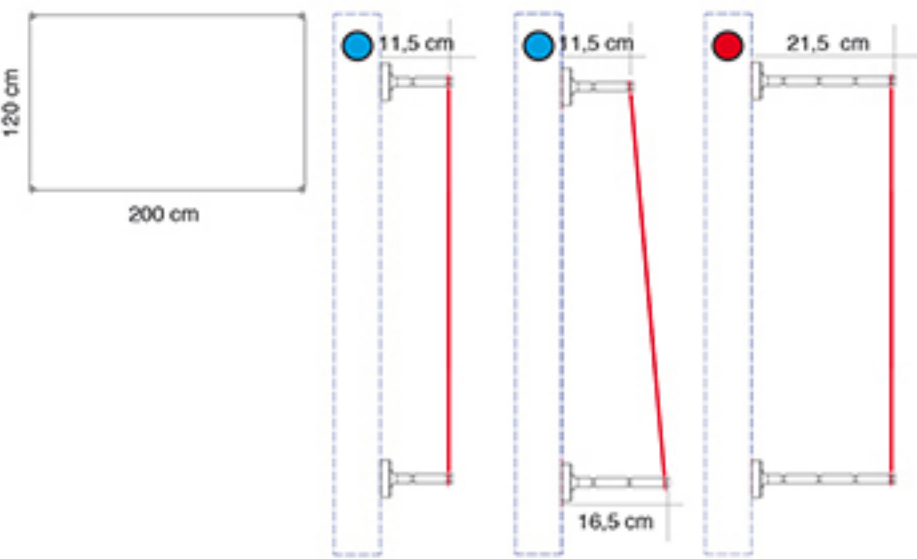
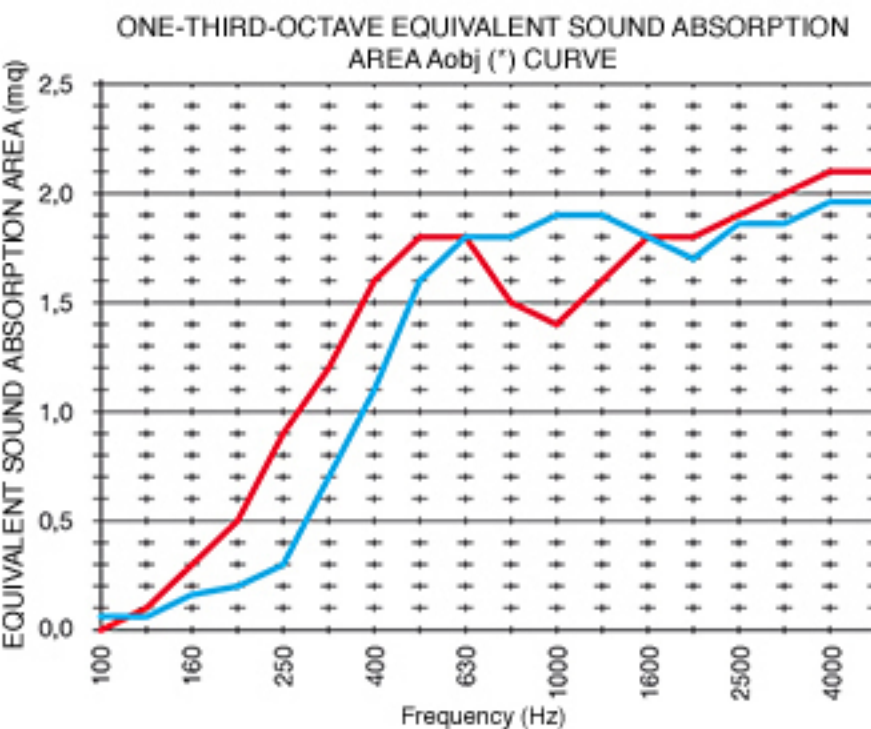

(*) In case of inclined panels, the values of Equivalent sound absorption area Aobj refer, as a precaution, to panels mounted straight with the shortest distance from the wall.

PALIO

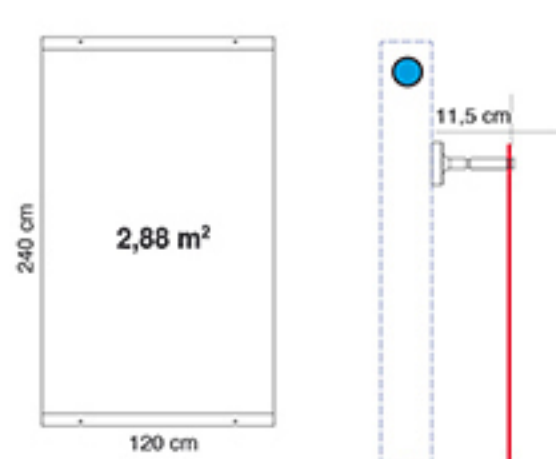
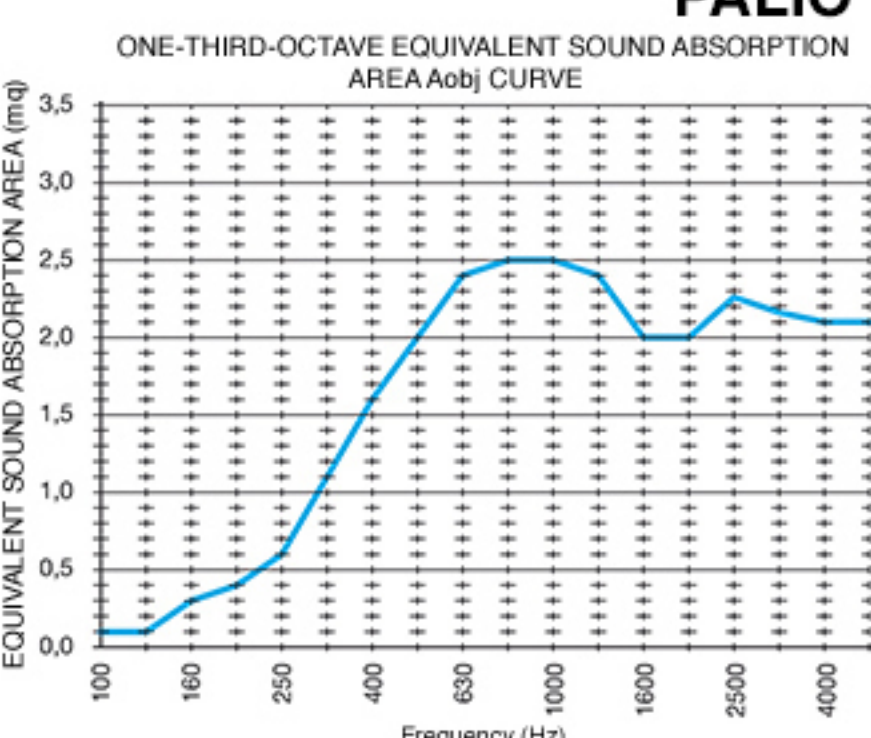

PALIO

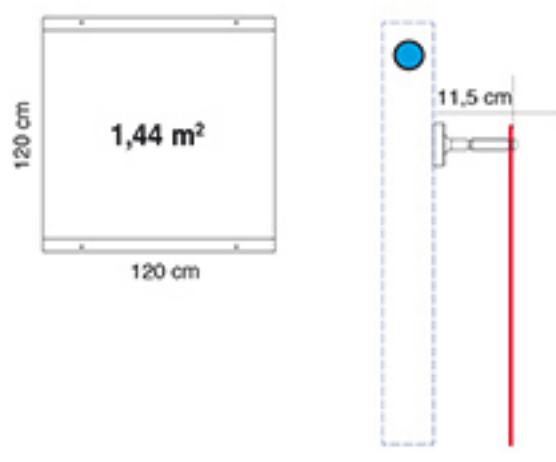
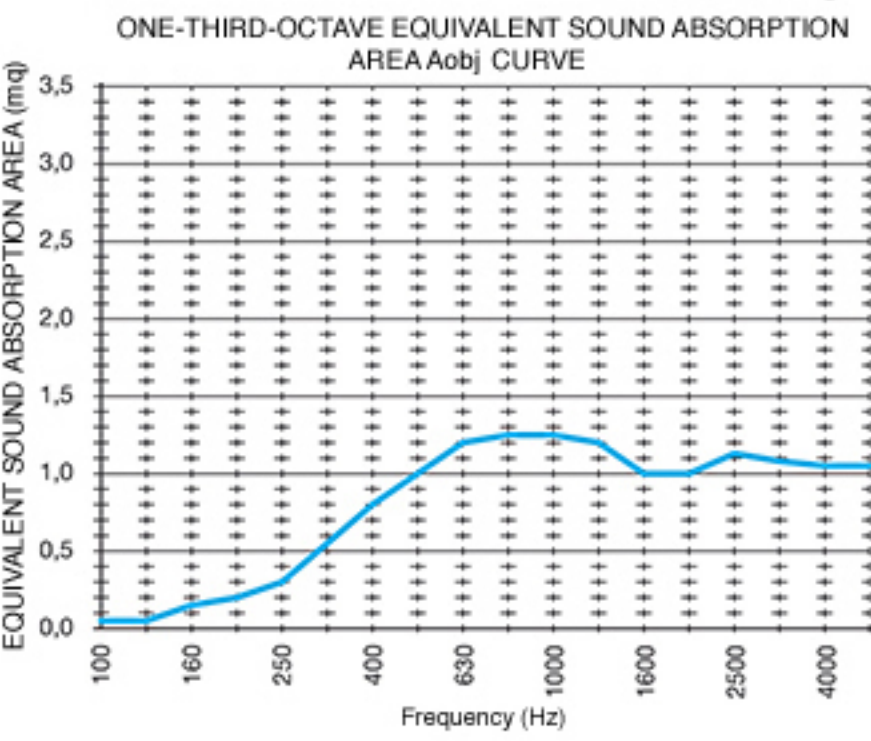

PALIO PRO

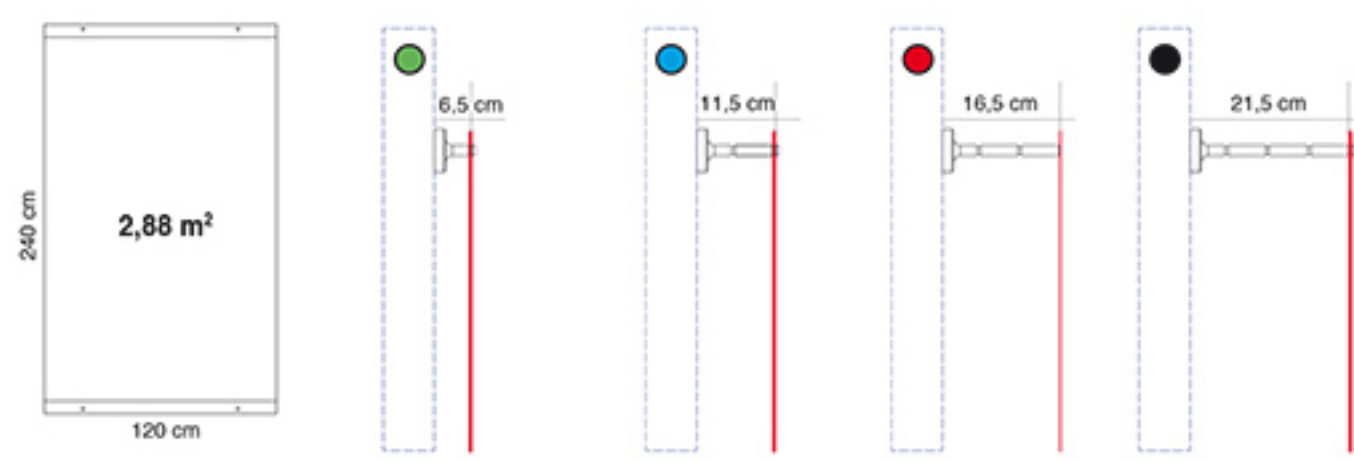
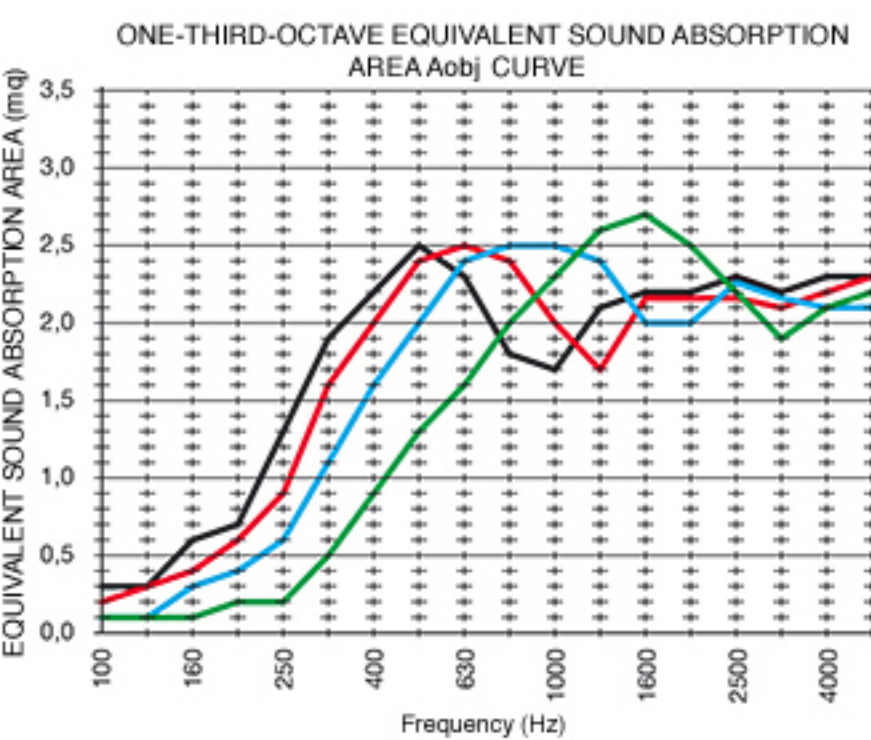

PALIO PRO

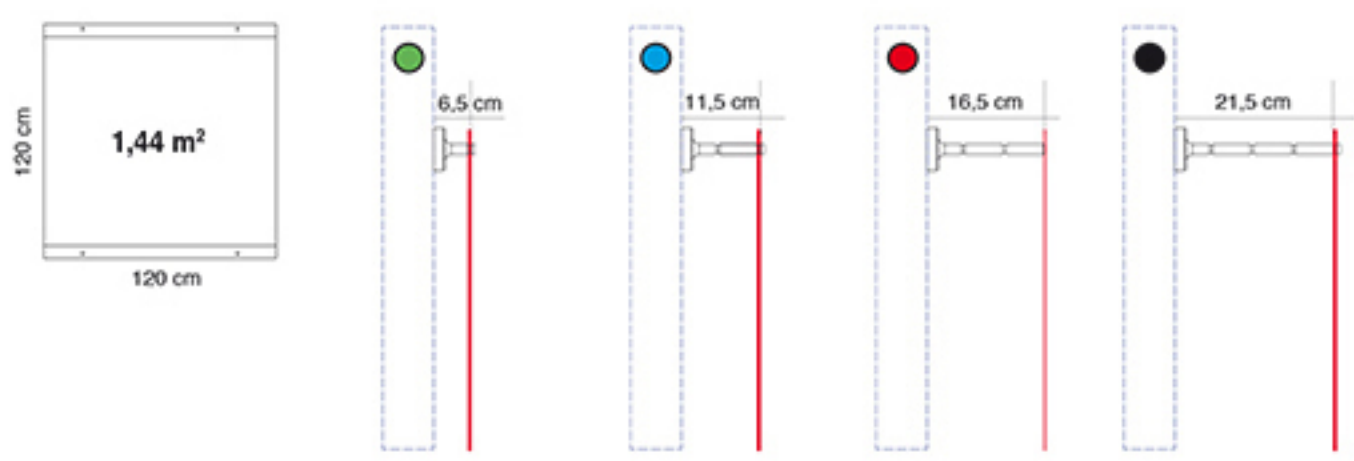
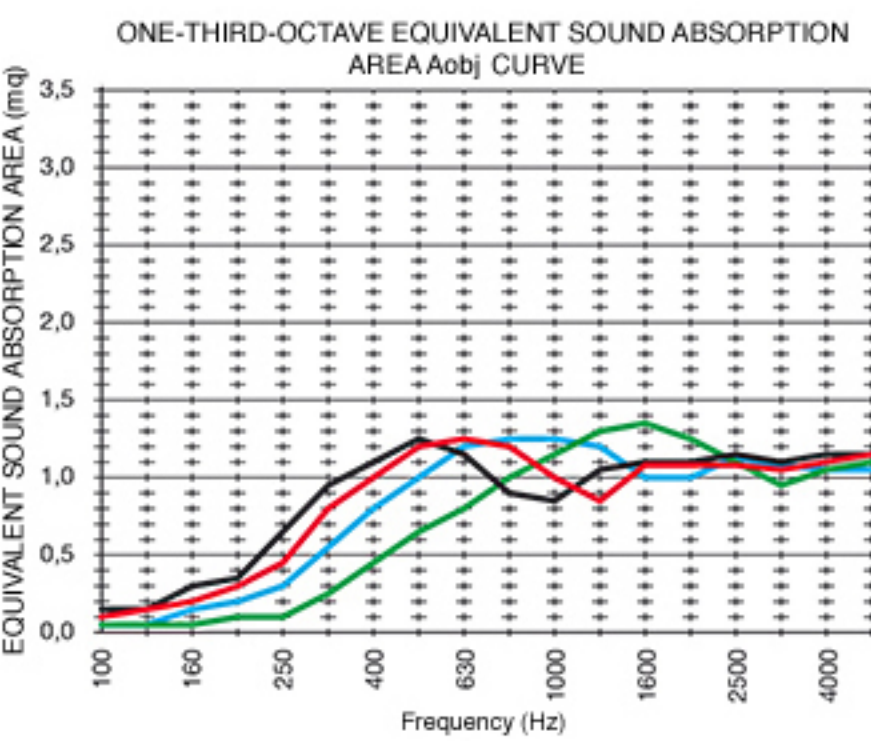

PALIO PRO

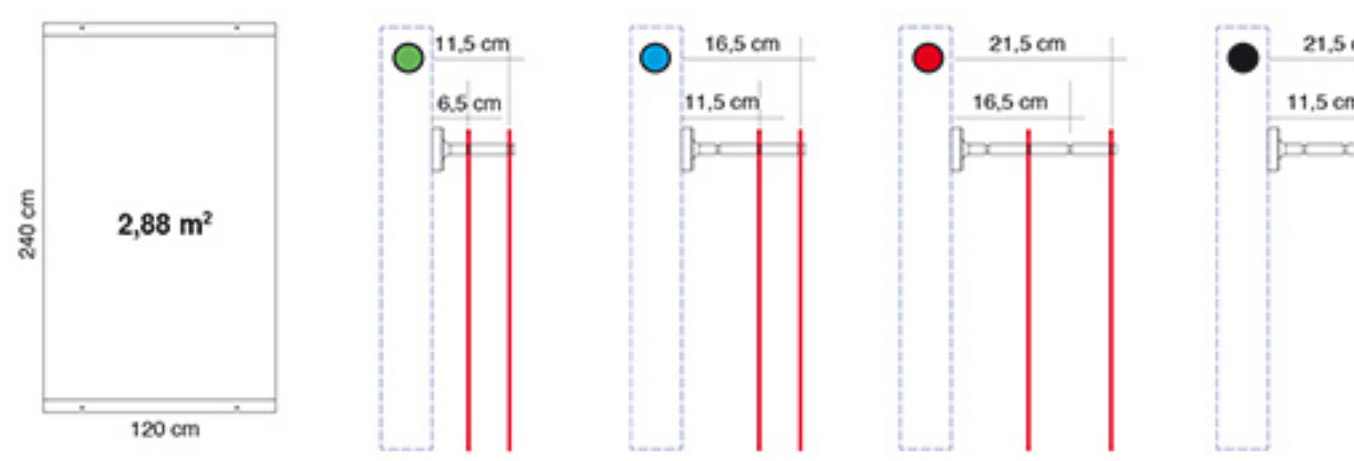
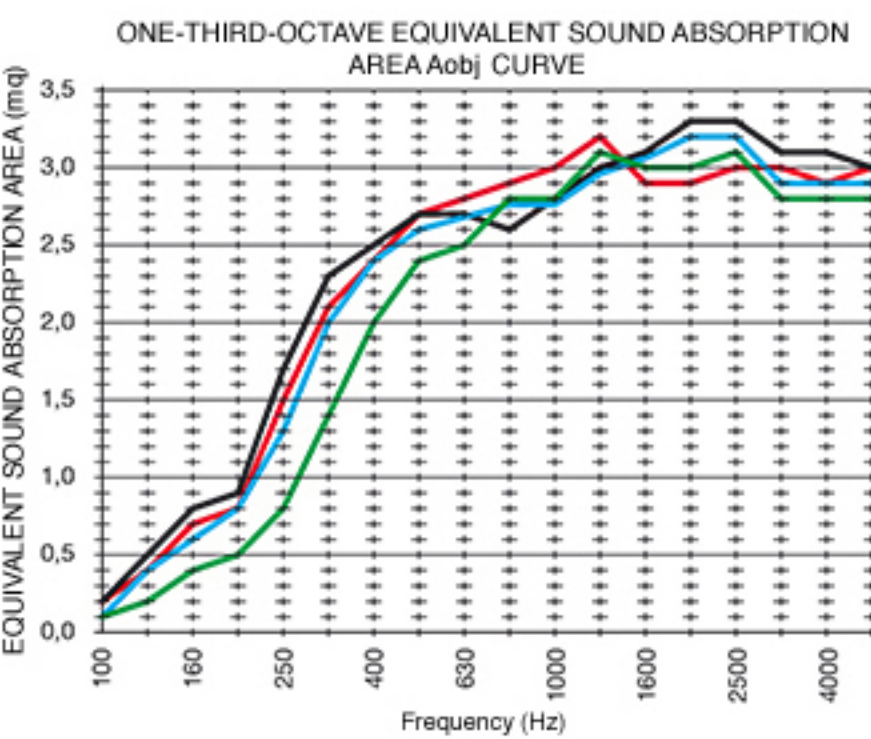

PALIO PRO

